

BRASS BALL VALVE SS LEVER F/F (DL)

GENERAL INDUSTRY VALVES

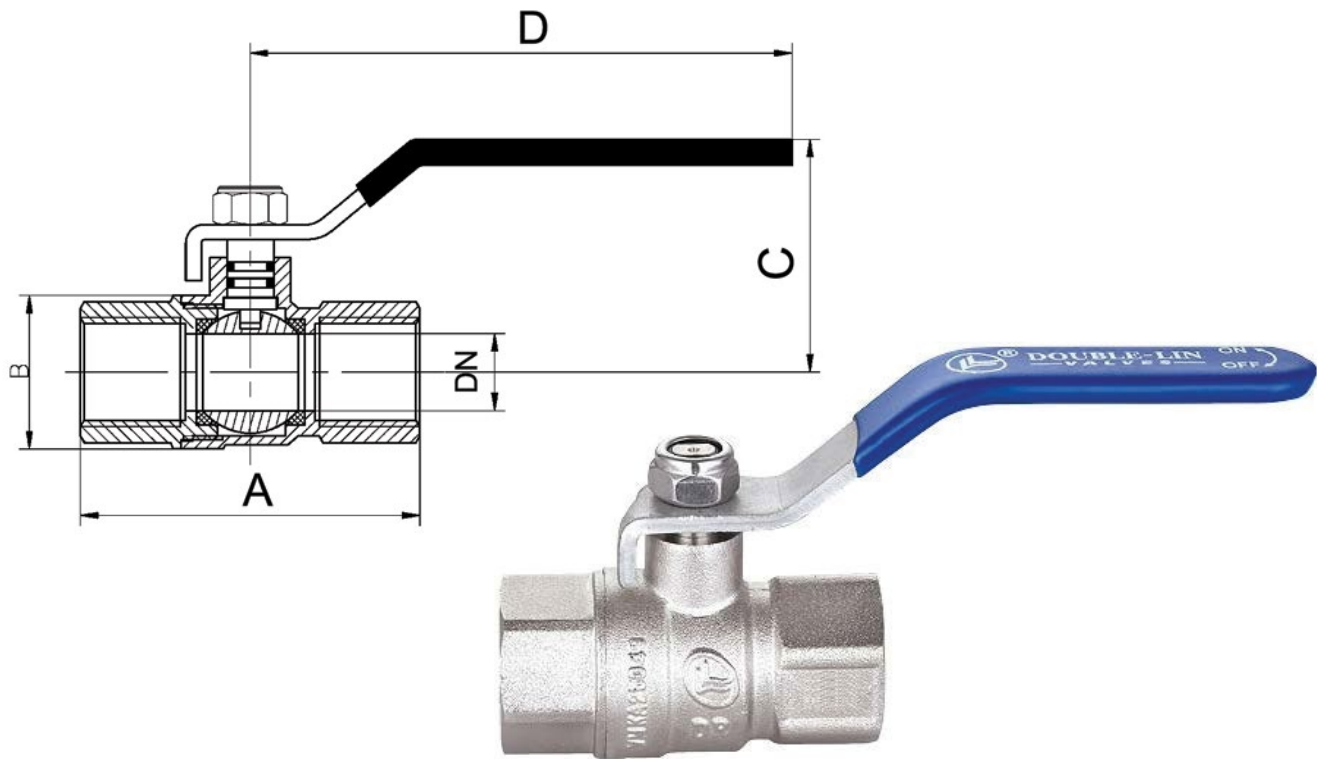

GVF CODE	DN SIZE (mm)	DN BORE (mm)	A (mm)	B (mm)	C (mm)	D (mm)	WEIGHT (kg)
BBVSS008	8	9	45	23	39.2	87	0.13
BBVSS010	10	10	45.8	23	39.8	87	0.12
BBVSS015	15	14.8	59.4	29.5	54.2	95	0.2
BBVSS020	20	19	67	35	57.6	95	0.29
BBVSS025	25	24	77	42.7	60.6	125	0.47
BBVSS032	32	30.2	93	53	75.8	140	0.72
BBVSS040	40	37	99	63	81.3	140	0.93
BBVSS050	50	47	117	79	88.5	165	1.48
BBVSS065	65	62	143	102.5	121.5	224	2.93
BBVSS080	80	74	165	120.5	129.5	224	4.28
BBVSS100	100	90	190	144.5	141	283.5	6.21

MATERIALS	
Body	NP Brass
Bonnet	NP Brass
Seal	PTFE
Ball	CP Brass
O Ring	Viton & NBR
Stem	Brass
Handle	Stainless Steel
Nut	NP Brass

SPECIFICATIONS
Max Working Temperature
120°C
Cold Working Pressure
2500 kPa

STANDARD
Thread
BSP to ISO 228-1