

DR BRASS GATE VALVES

GATE VALVES

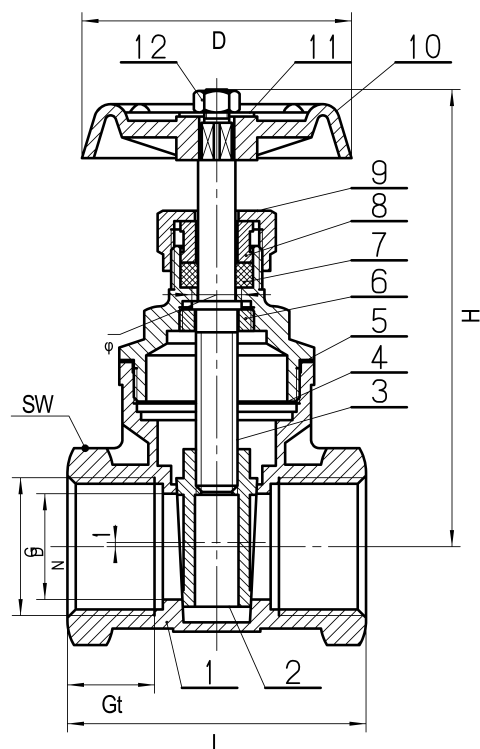

GVF CODE	SIZE (mm)	DN (mm)	L (mm)	H (mm)	Gt (mm)	SW (mm)	D (mm)	φ (mm)	WEIGHT (kg)
BGVD015	15	13	57	80	16	28	59.5	10	0.4
BGVD020	20	20	62	96.5	17.5	34	59.5	10	0.5
BGVD025	25	25.5	72	110	21	42	65	12	0.8
BGVD032	32	32	82.5	130	24	51	80	12	1.1
BGVD040	40	39	85.5	145.5	24	58	80	14	1.6
BGVD050	50	50	98	173	28	72	100	16	2.5
BGVD065	65	65	105	198	30	86	117	16	3.6
BGVD080	80	80	117	230	31.5	98	140	16	5.1
BGVD100	100	99	133	261	36	125	140	16	9.1

MATERIALS	
1. Body	DZR Brass
2. Wedge Disc	DZR Brass
3. Stem	DZR Brass
4. Bonnet	DZR Brass
5. Washer	PTFE
6. Localizer	DZR Brass
7. Packing	PTFE
8. Gland	DZR Brass
9. Packing Screw	DZR Brass

10. Handwheel	Cast Iron
11. T Handle	DZR Brass
12. ID Plate	Aluminium
13. Nut	DZR Brass

SPECIFICATIONS
Max Working Temperature
150°C
Cold Working Pressure
2500 kPa

STANDARD
Thread
Conforms to AS1628

