

STAINLESS STEEL 2PC BALL VALVE

STAINLESS STEEL VALVES

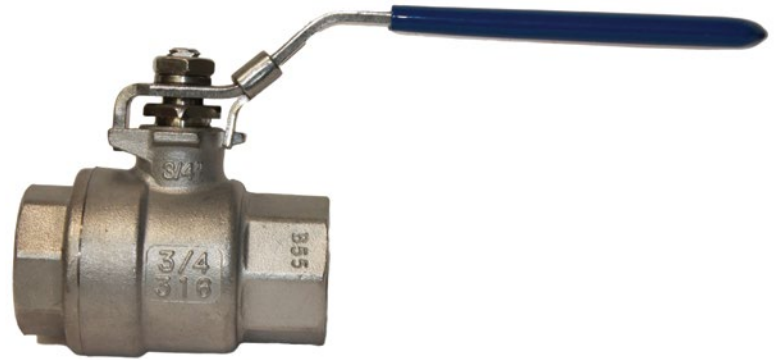
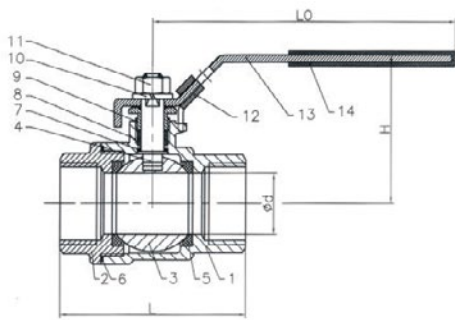

GVF CODE	DN SIZE (mm)	Ød (mm)	L (mm)	H (mm)	L0 (mm)	WEIGHT (kg)
SSBV2P008	8	11.6	48	48	100	0.18
SSBV2P010	10	11.6	48	48	100	0.19
SSBV2P015	15	15	58	52	100	0.26
SSBV2P020	20	20	65.7	61	127	0.42
SSBV2P025	25	25	77	65	127	0.61
SSBV2P032	32	32	90	79	154	1.01
SSBV2P040	40	38	98	83	154	1.37
SSBV2P050	50	50	121	97	192	2.52
SSBV2P065	65	65	145	135	244	4.83
SSBV2P080	80	80	166	144	244	7.45
SSBV2P100	100	100	240	159	275	17

MATERIALS	
Body	CF8M
Cap	CF8M
Stem	SS316
Ball	CF8M
Seat	PTFE + 3% GF
Gasket	PTFE
Thrust Washer	PTFE
Stem Packing	PTFE
Nut	SS304
Spring Washer	SS304
Nut	SS304
Stopper	SS304
Handle	SS304
Handle Sleeve	PVC

SPECIFICATIONS
Max Working Temperature
150°C @ 75 PSI
Cold Working Pressure
1000 PSI
Not recommended for steam

STANDARD
Thread
BSP to ISO 7-1
Pressure Test
API 598

