

# DUO WAFER CHECK CHECK VALVES

VALVES

GALVANISED  
MALLEABLE

STAINLESS  
STEEL FITTINGS

BLACK & GAL  
STEEL FITTINGS

HIGH PRESSURE  
FITTINGS

CAMLOCKS

ROLL GROOVE

BUTTWELD

FLANGES

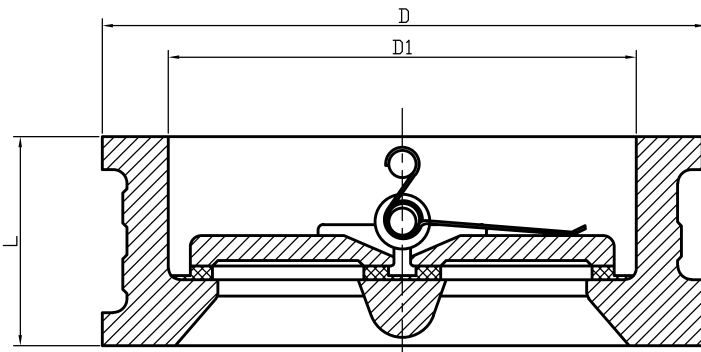

GVF CODE	DN SIZE (mm)	D (mm)	D1 (mm)	L (mm)	WEIGHT (kg)
WCV050	50	96	65	43	1.46
WCV065	65	109	80	46	2.19
WCV080	80	128	94	64	3.5
WCV100	100	160	117	64	4.34
WCV125	125	192	145	70	6.13
WCV150	150	212	170	76	8.89
WCV200	200	269	224	89	14.04
WCV250	250	333	265	114	26.43
WCV300	300	381	310	114	35.37
WCV350	350	444	360	127	45.64
WCV400	400	495	410	140	62.67
WCV450	450	558	450	152	86.94
WCV500	500	611	505	152	102.18
WCV600	600	723	624	178	182.56

MATERIALS	
Body	Cast Iron FBE
Disc	CF8M
Stem	SS316
Spring	SS316
Seat	NBR
Face Gasket	NBR

SPECIFICATIONS
Max Working Temperature
80°c
Cold Working Pressure
1600 kPa

STANDARD
Face to Face
API609, BS3135
Pressure Test
API 598